



# ELECTRIC WET/DRY VACUUM

8.5-AMP | 4-GAL | 3.5 PEAK HP | CYCLONE FILTRATION

## OPERATOR'S MANUAL

A Division of Snow Joe®, LLC

Model SWD4000

Form No. SJ-SWD4000-880E-M

## IMPORTANT! Safety Instructions

### All Operators Must Read These Instructions Before Use

Any electrical appliance can be dangerous if used incorrectly. Some of the safety precautions given in this manual apply generally to many appliances. Other warnings are specific to the use of this electric wet/dry vacuum.

Always follow these safety guidelines. Failure to do so may result in personal injury or property damage.

**⚠️WARNING!** This unit can be dangerous! Careless or improper use can cause serious injury.

### General Safety FOR HOUSEHOLD USE ONLY

Before using, be sure that everyone using this tool reads and understands all safety instructions and other information contained in this manual. Save this manual and review it frequently prior to using this tool and when instructing others on the proper operating procedures.

**⚠️CAUTION!** Wear appropriate hearing protection during use. After long periods of extended use, the noise generated from this appliance may cause hearing loss if your ears are not properly protected.

**⚠️WARNING!** To reduce the risk of injury, inspect the filters frequently and replace with recommended replacement if there are signs of wear or deterioration.

Before using the wet/dry vacuum, take the time to familiarize yourself with the controls, especially how to stop the wet/dry vacuum in an emergency. The only individuals who should use the wet/dry vacuum are those who have a thorough understanding of the instructions and who know how to operate the machine. Children should never be allowed access to the wet/dry vacuum.

Retain this manual for future reference.

1. **Keep filters in place** – Ensure that the equipment is assembled correctly and the filters are in the correct position.

2. **Keep bystanders and children away** – All bystanders, including children and pets, should be kept a safe distance away from the work area.
3. **Disconnect tool** – Disconnect the wet/dry vacuum from the power supply when not in use, before servicing, when transporting, or when changing accessories.
4. **Do not use in dangerous environments** – Do not use the wet/dry vacuum in rain, damp or wet locations. Do not operate the wet/dry vacuum in gaseous or explosive atmospheres or use the wet/dry vacuum to pick up flammable or combustible liquids. Motors in these tools normally spark, and the sparks might ignite fumes.
5. **Check for damaged parts** – Before using the wet/dry vacuum, repair or replace any part that is damaged. In addition, check for alignment of moving parts, binding of moving parts, breakage of parts, and any other conditions that may affect the tool's operation.

Inspect the appliance cord periodically. If damage is found, have it repaired by an authorized service facility. Extension cords should also be inspected periodically and immediately replaced if damaged.

6. **Avoid unintentional starting** – Make sure the switch is off before plugging in the appliance.
7. **Use the right tool** – Do not force the tool or any attachment on the tool to do a job for which they were not designed.
8. **Wear face or dust masks** – If operated in dusty environment, the use of a face or dust mask specially designed to filter out microscopic particles is recommended.
9. **Maintain tools with care** – Keep tools clean for best and safest performance. Follow instructions for changing accessories. If the appliance is not working as it should, or has been dropped, damaged, left outdoors, dropped into water, please call Snow Joe® + Sun Joe® customer service center at 1-866-SNOWJOE (1-866-766-9563).
10. **Use recommended accessories** – Consult the owner's manual for recommended accessories. The use of improper accessories may cause risk of injury.
11. **Do not abuse the cord** – Never carry the appliance by its cord or yank it to disconnect it from the receptacle. Keep the cord away from heat, oil, and sharp edges.
12. **Do not force the appliance** – It will do the job better and with less likelihood of a risk of injury if it is used at the rate for which it was designed.
13. **Do not overreach** – Keep proper footing and balance at all times.

- 14. **Store idle tool indoors** – When not in use, the wet/dry vacuum should be stored indoors in a dry and locked-up place out of the reach of children.
- 15. **Stay alert** – Watch what you are doing. Use common sense. Do not operate the wet/dry vacuum when you are tired or under the influence of drugs, alcohol or other medication.

**⚠ DANGER!** Do not manually place objects into the vacuum inlet while operating the unit, as this can seriously damage the unit and/or harm the operator. Keep both hands away from the air inlet while the power is on.

**DO NOT ATTEMPT** to remove material or hold material to be vacuumed when the wet/dry vacuum is on. Make sure the wet/dry vacuum is off when clearing jammed material from the vacuum inlet.

## Personal Safety

**⚠ DANGER!** Do not vacuum, or use this wet/dry vacuum near flammable liquids, gases, or explosive vapors like gasoline or other fuels, light fluids, cleaners, oil-based paints, natural gas, hydrogen, or explosive dusts like coal dust, magnesium dust, grain dust or gun powder. Sparks generated by the motor can ignite flammable vapors or dust.

- This vacuum is only for indoor use. Do not use it outdoors.
- Children in the work area must be supervised to ensure that they do not play with the appliance. This appliance is NOT a toy and should never be used as such.
- Never leave a machine that is ready for operation unattended at the workplace.
- Do not use the tool with a damaged plug. If the tool is not working as it should or has been dropped, damaged, left outdoors or dropped into water, contact the Snow Joe® + Sun Joe® customer service department at 1-866-SNOWJOE (1-866-766-9563).
- Do not pick up anything that is burning or smoking, such as cigarettes, matches or hot ashes.
- Do not use without the power head and/or filters in place.
- Carefully inspect your appliance prior to use and follow all label and marking instructions.
- Always unplug this appliance before assemble or disassemble the filter.
- Do not handle plug or the unit with wet hands.
- To reduce the risk of health hazard from vapors or dust, do not vacuum toxic material.
- Do not store near hazardous material.
- Do not leave the wet/dry vacuum unattended when plugged in. Unplug from the power source when not in use.
- Keep hair, loose clothing, fingers, and all parts of the body away from openings.

- Maintain proper footing and use extra care when using the appliance on stairs.
- Service on the product must be performed by qualified repair personnel only. Service or maintenance performed by unqualified personnel could result in injury to the user or damage to the product.
- This wet/dry vacuum is intended for residential use only. Commercial use of this product is prohibited and will void the manufacturer's warranty.
- Never douse or squirt the unit with water or any other liquid. Clean the unit after use every time as described in the cleaning and storage section.
- Prevent cords, plastic bags, or similar items from getting sucked in, as these might wrap around the filter, which may cause an overload or blocking of the motor. In such a case, switch the wet/dry vacuum off. Do not leave the wet/dry vacuum switched on with the motor overloaded or stalled.
- Always operate the machine in an upright position. Do not operate it tilted to one side or even upside-down.

## Electrical Safety

1. Ground fault circuit interrupter (GFCI) protection should be provided on the circuit(s) or outlet(s) to be used for this electric wet/dry vacuum. Receptacles are available having built-in GFCI protection and may be used for this measure of safety.
2. Make sure that the mains voltage matches that listed on the unit's rating label. Using the improper voltage can damage the motor and injure the user.
3. To prevent electric shock, use only with an extension cord suitable for indoor use only, such as SW-A, SOW-A, STW-A, STOW-A, SJW-A, SJOW-A, SJTW-A, or SJTOW-A.

Before use, check that the extension cord is in good condition. When using an extension cord, make sure to use one heavy enough to carry the current your product will draw. An undersized cord will cause a drop in line voltage resulting in loss of power and overheating.



## WARNING



**Electric shock may cause SEVERE INJURY or DEATH. Heed these warnings:**

- Do not allow any part of the electric wet/dry vacuum to make contact with water while it is in operation. If the appliance becomes wet while turned off, wipe dry before starting.
- Do not use an extension cord over 7.5 ft. The wet/dry vacuum comes equipped with a 6 ft power cable. Combined cord length must not exceed 13.5 ft. Any extension cord must be 18-gauge (or heavier) to safely power the wet/dry vacuum.
- Do not touch the appliance or its plug with wet hands or while standing in water. Wearing rubber boots offers some protection.

### EXTENSION CORD CHART

Cord Length:	7.5 ft (2.3 m)
Min. Wire Gauge (A.W.G.):	18

4. To reduce the risk of electric shock, this appliance has a polarized plug (i.e. one blade is wider than the other). Use this appliance only with a polarized UL-, CSA- or ETL-listed extension cord recommended for indoor use only.

The appliance plug will fit into a polarized extension cord only one way. If the appliance plug does not fit fully into the extension cord, reverse the plug. If the plug still does not fit, obtain a correct polarized extension cord. A polarized extension cord will require the use of a polarized wall outlet. The extension cord plug will fit into the polarized wall outlet only one way. If the plug does not fit fully into the wall outlet, reverse the plug. If the plug still does not fit, contact a qualified electrician to install the proper wall outlet. Do not modify the appliance plug, extension cord receptacle or extension cord plug in any way.

5. To prevent the appliance cord from disconnecting from the extension cord during operation, make a knot with the two cords as shown in Table 1.

**Table 1. Method of Securing Extension Cord**

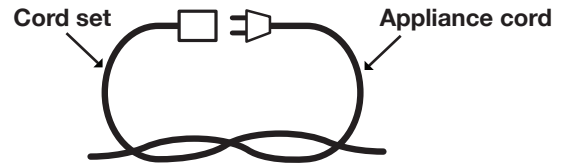

**(A) Tie cord as shown**

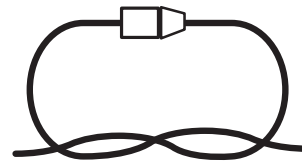

**(B) Connect plug and receptacle**

6. Do not abuse the cord. Never pull the wet/dry vacuum by the cord or yank the cord to disconnect it from the receptacle. Keep the cord away from heat, oil and sharp edges.

## Double-Insulated Appliances

In a double-insulated appliance, two systems of insulation are provided instead of grounding. No grounding means is provided on a double-insulated appliance, nor should a means for grounding be added to the appliance. Servicing a double-insulated appliance requires extreme care and knowledge of the system, and should be performed only by qualified service personnel at an authorized Snow Joe® + Sun Joe® dealer. Replacement parts for a double-insulated appliance must be identical to the parts they replace. A double-insulated appliance is marked with the words "Double Insulation" or "Double Insulated." The symbol  (square within a square) may also be marked on the appliance.



**DOUBLE-INSULATED: GROUNDING NOT REQUIRED. WHEN SERVICING, USE ONLY IDENTICAL REPLACEMENT PARTS.**

This electric wet/dry vacuum is double-insulated, eliminating the need for a separate grounding system. Use only identical replacement parts. Read the instructions before servicing double-insulated appliances. Use this wet/dry vacuum only as described in this manual.

# Specific Safety Rules for Wet/Dry Vacuum

This motor-operated wet/dry vacuum is intended for vacuuming wet or dry material and dust. This equipment is not suitable for vacuuming ashes, coals, toxic, flammable or other hazardous materials. Vacuuming of glowing materials and dusts that are combustible, explosive or hazardous to one's health is prohibited. The manufacturer will not be held responsible for injuries resulting from incorrect use of the device or from use that does not comply with the directions.

**NOTE:** This wet/dry vacuum is intended for indoor household use only.

**⚠️WARNING!** To reduce the risk of electric shock, do not use outdoors or in damp or wet environments. Do not expose to rain. Store indoors in a dry place.

**⚠️WARNING!** For your own safety, read and understand the operator's manual. Do not run the unit unattended. Do not pick up hot ashes, coals, toxic substances, flammable materials or other hazardous debris. Do not use the device in an area with explosive liquids or vapors.

**⚠️CAUTION!** To reduce the risk of injury, unplug the unit before servicing.







- Do not use the wet/dry vacuum without filters in place.
- When vacuuming, do not place the equipment on heat sensitive floors. For safety reasons, use a fireproof base when necessary.
- Empty and clean the vacuum before and after vacuuming to avoid the accumulation of debris.

**⚠️CAUTION!** Do not vacuum hazardous substances (e.g. petrol, solvents, acids or lyes) and ash from unauthorized fuels (i.e. from oil-burning ovens or heating boilers). These substances pose a serious risk of injury.

- Do not use the vacuum in areas where flammable or combustible liquids, such as gasoline, may be present.
- Do not vacuum fine, combustible dust particles that can ignite and potentially lead to an explosion.
- Do not put foreign objects into openings. Do not use the vacuum with any opening blocked; keep all openings free of dust, lint, hair, and anything that may reduce air flow.
- Always check the hose and the unit when vacuuming.

# Safety Symbols

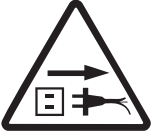
The following table depicts and describes safety symbols that may appear on this product. Read, understand and follow all instructions on the machine before attempting to assemble and operate.

Symbols	Descriptions	Symbols	Descriptions
	Safety alert. Exercise caution.		To reduce the risk of injury, user must read the instruction manual.
	To reduce the risk of electric shock, do not use outdoors or in damp or wet environments. Do not expose to rain. Store indoors in a dry place.		<b>WARNING!</b> Always turn the machine OFF and disconnect the electrical power before conducting inspection, cleaning and maintenance. Remove the plug from the outlet immediately if the cord is damaged or cut.
	Immediately remove the plug from the mains if the power cable is damaged, frayed or entangled. Always keep the power cable away from heat, oil and sharp edges.		<b>DOUBLE INSULATION –</b> When servicing, use only identical replacement parts.

# Know Your Electric Wet/Dry Vacuum

Read the owner's manual and safety instructions carefully before operating the electric wet/dry vacuum. Compare the illustration below to the electric wet/dry vacuum in order to familiarize yourself with the location of the various controls and adjustments. Save this manual for future reference.

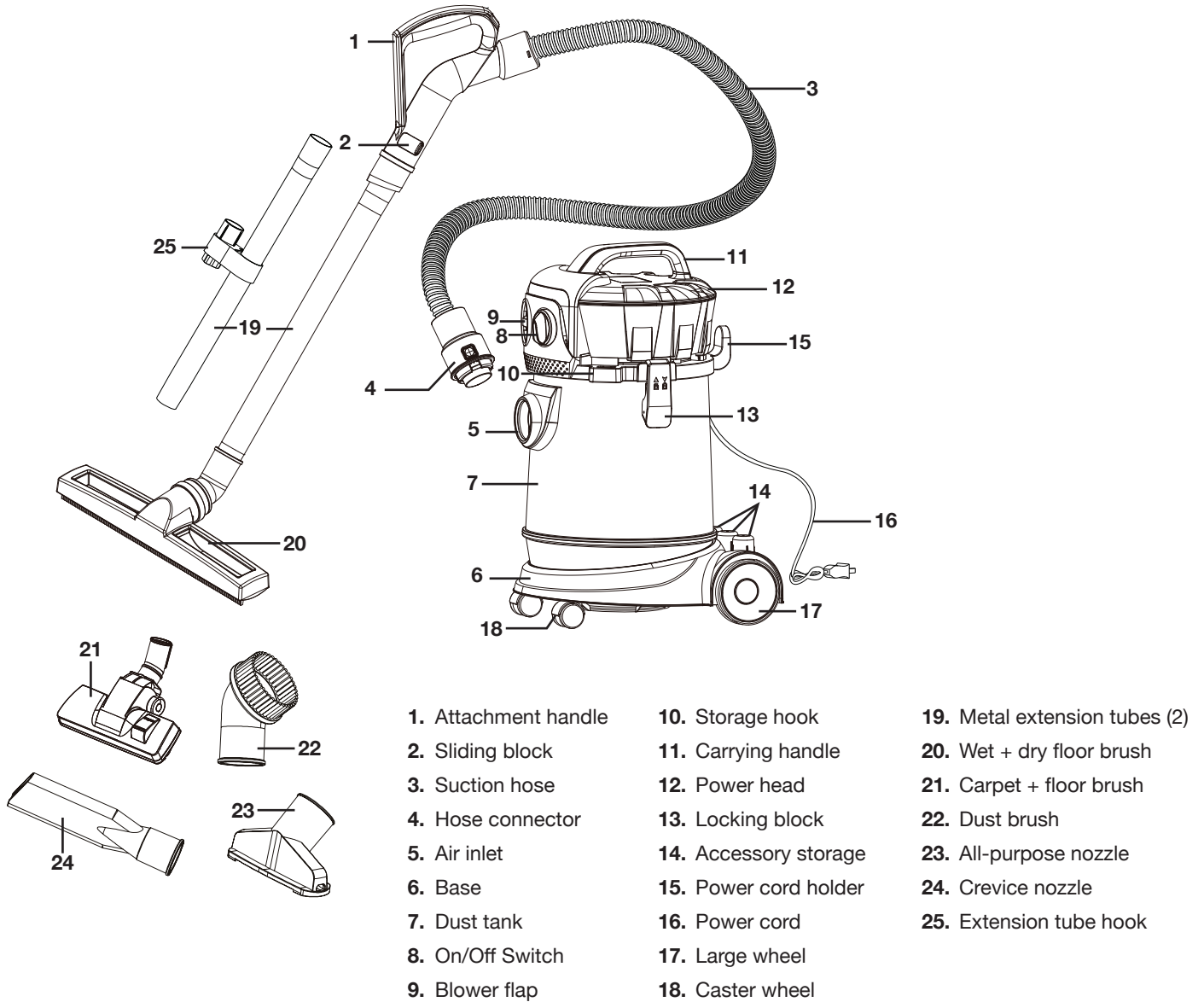

- |                      |                       |                               |
|----------------------|-----------------------|-------------------------------|
| 1. Attachment handle | 10. Storage hook      | 19. Metal extension tubes (2) |
| 2. Sliding block     | 11. Carrying handle   | 20. Wet + dry floor brush     |
| 3. Suction hose      | 12. Power head        | 21. Carpet + floor brush      |
| 4. Hose connector    | 13. Locking block     | 22. Dust brush                |
| 5. Air inlet         | 14. Accessory storage | 23. All-purpose nozzle        |
| 6. Base              | 15. Power cord holder | 24. Crevice nozzle            |
| 7. Dust tank         | 16. Power cord        | 25. Extension tube hook       |
| 8. On/Off Switch     | 17. Large wheel       |                               |
| 9. Blower flap       | 18. Caster wheel      |                               |

## Technical Data

Rated Voltage.....	120 V ~ 60 Hz	Suction Hose Length.....	4.9 ft (1.5 m)
Motor.....	8.5 A	Tank Capacity.....	4 gal (15.1 L)
Air Flow.....	50 CFM (1.4 m <sup>3</sup> /min)	Filtration.....	Multi-cyclone + foam
Peak Horsepower.....	3.5 HP	Power Cord Length.....	6 ft (1.8 m)
Vacuum Pressure Max.....	19.5 kPa	Weight.....	20.3 lbs (9.2 kg)
Suction Power Max (Air Watts).....	140 W		

# Unpacking

## Carton Contents

- Electric wet/dry vacuum
- Suction hose
- Extension tubes (2)
- Wet + dry floor brush
- Carpet + floor brush
- Dust brush
- All-purpose nozzle
- Crevice nozzle
- Manuals + Registration card

1. Carefully remove the electric wet/dry vacuum and check to see that all of the above items are supplied.
2. Inspect the product carefully to make sure no breakage or damage occurred during shipping. If you find damaged or missing parts, DO NOT return the unit to the store. Please call the Snow Joe® + Sun Joe® customer service center at 1-866-SNOWJOE (1-866-766-9563).

**NOTE:** Do not discard the shipping carton and packaging material until you are ready to use the wet/dry vacuum. The packaging is made of recyclable materials. Properly dispose of these materials in accordance with local regulations.

**IMPORTANT!** The equipment and packaging material are not toys. Do not let children play with plastic bags, foils or small parts. These items can be swallowed and pose a suffocation risk!

## Assembly

**⚠ WARNING!** To avoid serious personal injury, read and understand all safety instructions provided.

**⚠ WARNING!** Do not connect to power supply until assembly is complete. Failure to comply could result in accidental starting and possible serious personal injury.

**⚠ WARNING!** Before performing any maintenance, make sure the tool is unplugged from the power supply. Failure to heed this warning could result in serious personal injury.

**⚠ WARNING!** To prevent personal injury, make sure the switch is in the OFF position before attaching or removing the suction hose.

1. Simultaneously depress the dual locking buttons on either side of the hose connector. Insert the hose connector into the air inlet hole and push firmly to secure (Fig. 1).

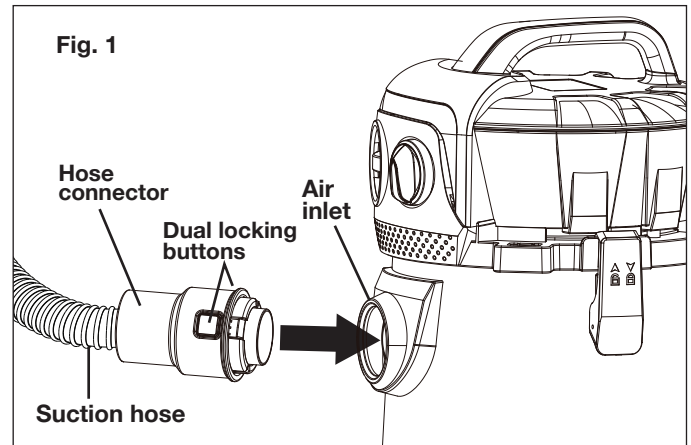

2. Two extension tubes are included with the unit. If needed, take the slightly narrowed end of the first extension tube and using a twisting motion, insert into the attachment handle. Press firmly to secure. In the same manner, assemble the second tube (Fig. 2).

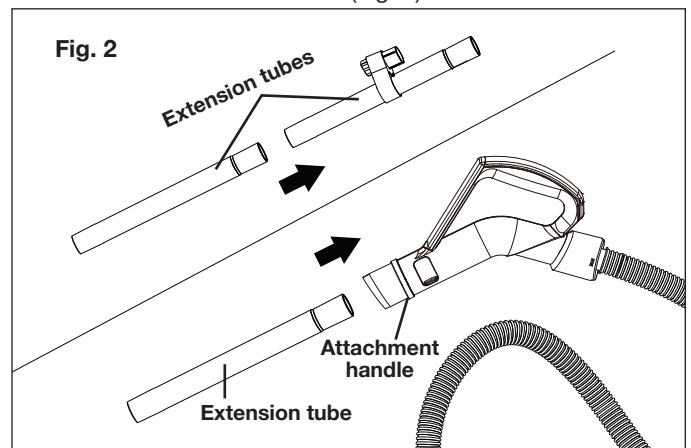

3. Select desired accessory, connect it with the end of the extension tube, press firmly to lock securely. Your wet/dry vacuum is ready for use. If no extension is needed, connect the desired accessory directly to the attachment handle (Fig. 3).

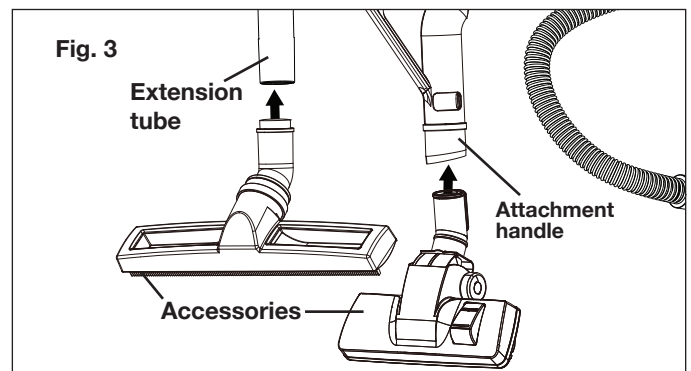

# Operation

**⚠️WARNING!** This equipment incorporates parts such as switches, motors or the like that tend to produce arcs or sparks that can cause an explosion. Do not pick up flammable, combustible, or hot materials. Do not use around explosive liquids or vapors, as electrical devices produce arcs or sparks which can cause a fire or explosion – do not use at filling stations or anywhere gasoline is stored or dispensed.

## Starting + Stopping

Do not switch on the wet/dry vacuum until it has been completely assembled. Before switching on the unit, always check the power cord for signs of damage. Use only intact cords.

**⚠️WARNING!** Damaged cords pose a severe risk of injury. Replace damaged cords immediately.

**⚠️WARNING!** Before switching on the wet/dry vacuum, make sure that it is not in contact with any foreign objects.

1. Make sure the filters are installed before starting.
2. Make sure the power head and the suction hose are installed properly and locked securely.
3. Install the desired brush attachment onto the end of the hose. Use the extension tubes if needed.
4. Check that the electrical supply voltage and frequency (Volt/Hz) correspond to those specified on the rating plate. Plug the power cord into the outlet (Fig. 4). If an extension cord is used, make a knot with the two cords as shown in Table 1.

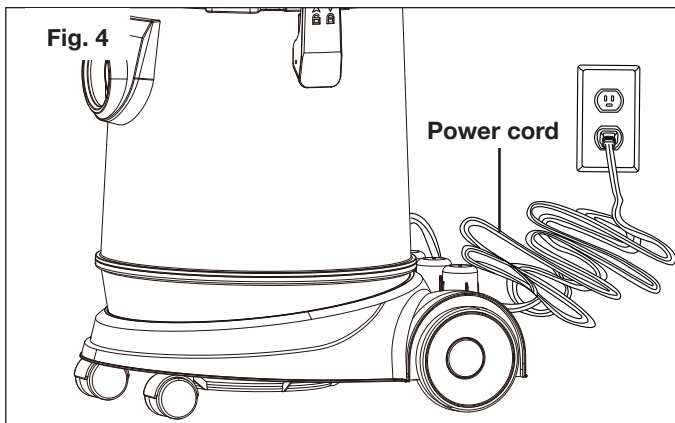

5. To start the unit, turn the ON/OFF switch to the ON position (Fig. 5), as indicated.

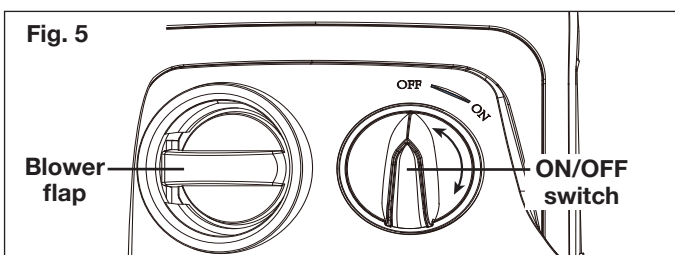

6. To stop the unit, turn the ON/OFF switch to the OFF position (Fig. 5), as indicated.
7. To adjust the strength of the airflow, push the sliding block on the attachment handle up or down (Fig. 6).

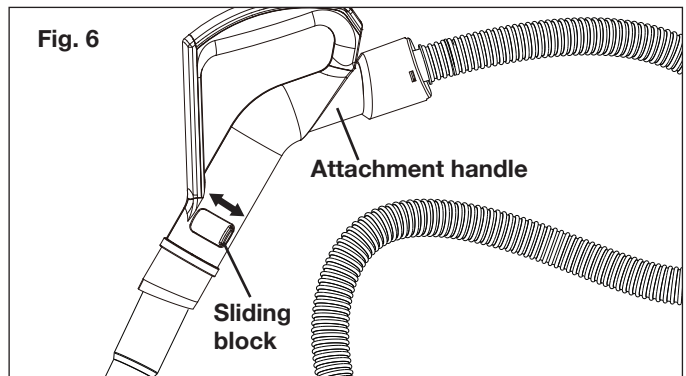

8. To use the blower function, make sure the unit is turned off. Then remove the hose from the air inlet hole and insert into the blower flap by depressing the dual locking buttons. Push firmly to secure (Fig. 7).

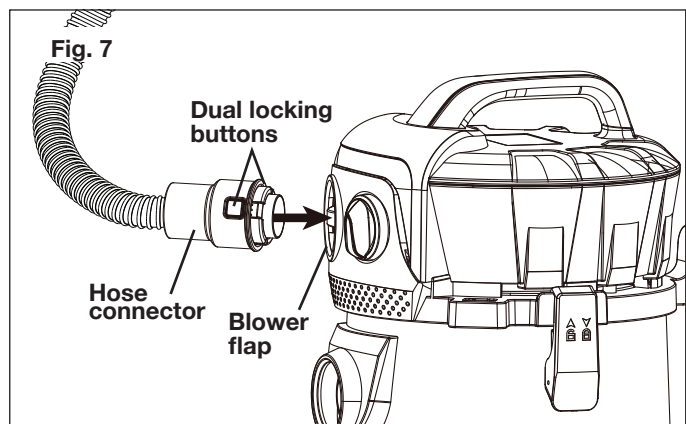

## Operating Tips

This electric wet/dry vacuum is designed to clean hard surfaces. It is only suitable for vacuuming wet or dry, light materials. The vacuuming of heavy materials such as metal, stones, branches, broken glass is expressly excluded.

**⚠️WARNING!** Use the wet/dry vacuum only in daylight or good artificial light.

- Make sure the power head is properly installed and secured when using. Make sure each lock is secured. Failure to properly secure the locks could cause the power head to release from the tank.
- Double check to make sure the filters are not broken or torn. Do not use filters that are broken or torn. Handle the filters carefully when removing and installing.
- To reduce the risk of hearing loss associated with sound level(s), hearing protection is required.
- Always direct the cord backwards, away from the unit.
- This unit is intended for indoor use only. Do not use this unit outdoors.



- Be extremely careful when working on slopes and stairs.
- Always move forward by walking. Never run.
- Clean up after using the wet/dry vacuum. Dispose of debris appropriately.
- Always use the carrying handle for transporting the equipment.

**⚠️ WARNING!** To avoid personal injury, wear ear protectors when operating this unit. Wear a face mask or dust mask in dusty locations.

## Air Inlet

Never cover the air inlets. Keep them free from obstructions and debris. They must always remain clear for proper motor cooling.

**⚠️ WARNING!** To avoid personal injury, do not wear loose fitting clothing or articles such as scarves, necklaces, chains, ties, etc., that could get drawn into the air inlet. To make sure long hair does not get drawn into the air inlet, tie back long hair.

## Basic Vacuum Procedures

**⚠️ WARNING!** Do not vacuum drywall dust, fireplace soot or ash with the unit. This is very fine dust which will not be captured by the filter and may cause damage to motor.

**⚠️ WARNING!** The foam filter must be used for wet vacuuming, and make sure to clean the foam filter after wet vacuuming.

- Place the equipment on a level surface that is not heat sensitive.
- Always use the suction hose for vacuuming. Hold the suction hose at a distance of approximately 0.4 in. (1 cm) above the material to be vacuumed.

**⚠️ WARNING!** When vacuuming large quantities of liquids, do not immerse the brush attachment completely in the liquid; leave a gap at the tip of the brush attachment opening to allow air inflow. The machine is fitted with a float valve that stops the suction action when the collection tank reaches its maximum capacity. You will notice a decrease in motor speed. When this happens, turn off the machine, disconnect from power supply, and drain the liquid into a suitable receptacle or drain. To continue vacuuming, refit the collection tank with the power head.

- To prevent overheating of the motor, stop the unit for one minute after every 15 minutes of using.
- Turn off and unplug the unit after vacuuming, before cleaning and maintenance. After wet vacuuming, empty the collection tank, clean and dry the inside and outside before storage.
- Empty the tank outside in order to avoid a mess.

- Clean or change the filters (see Maintenance section) if the suction performance deteriorates. Never use the appliance without the filter.

**⚠️ WARNING!** Never remove the power head without first turning the power switch to the OFF position and unplugging the unit from the main power source.

## Releasing and Assembling the Power Head

**⚠️ WARNING!** To prevent personal injury, make sure the switch is in the OFF position and the unit is unplugged before attaching or removing the power head.

1. To remove the power head, lift and release the locking blocks to open up the housing (Fig. 8).

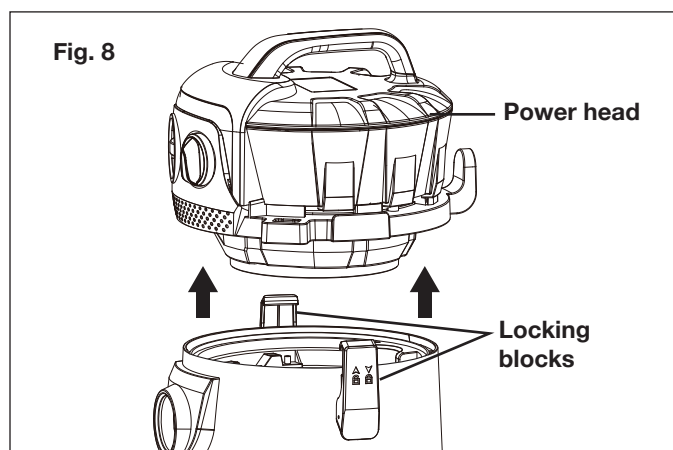

2. To reattach the power head, fit the power head onto the tank and fasten the locking blocks.

**NOTE:** The power head must be attached any time the unit is being operated.

## Maintenance

To order genuine replacement parts or accessories for the Sun Joe® SWD4000 electric wet/dry vacuum, please visit [snowjoe.com](http://snowjoe.com) or contact the Snow Joe® + Sun Joe® customer service center at 1-866-SNOWJOE (1-866-766-9563).

**⚠️ WARNING!** Disconnect the power cord before performing any maintenance task.

If the power is still connected, the unit could be accidentally turned on while you are performing maintenance on it, which could result in personal injury.

## Cleaning the Filters

**⚠️ WARNING!** The foam filter must be cleaned every time after wet vacuuming.

1. Switch off and unplug the unit. Take the unit outside to clean it to avoid creating a mess indoors.

2. Remove the power head from the collection tank.
3. Remove all the inner housing components as shown (Fig. 9).

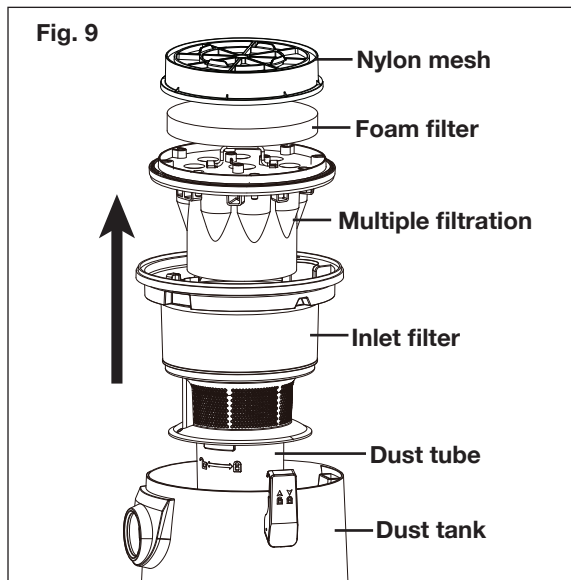

4. Separate the dust tube from the inlet filter by rotating clockwise to unlock (Fig. 10).

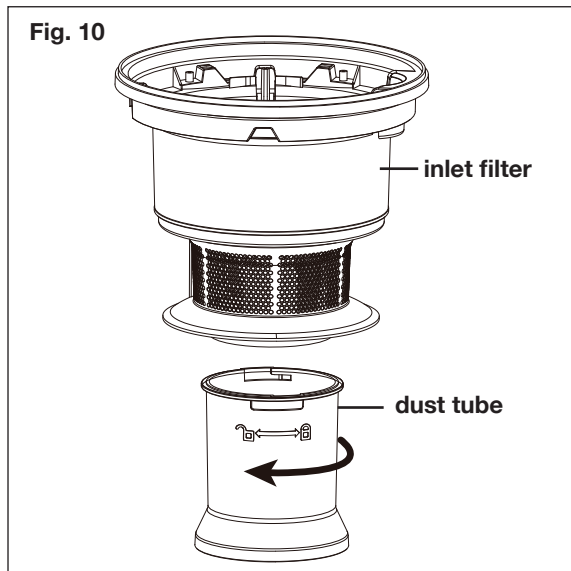

5. Use a mild soap and water solution to wash all the housing components and rinse with clean water. Allow the filters and housing to air dry for 24 hours before re-installing.

## Cleaning The Dust Tank

Clean the equipment routinely after each use:

1. Before all the inner housing components are re-installed, empty the dust tank (Fig. 11). Clean the tank with water and allow it to dry completely.

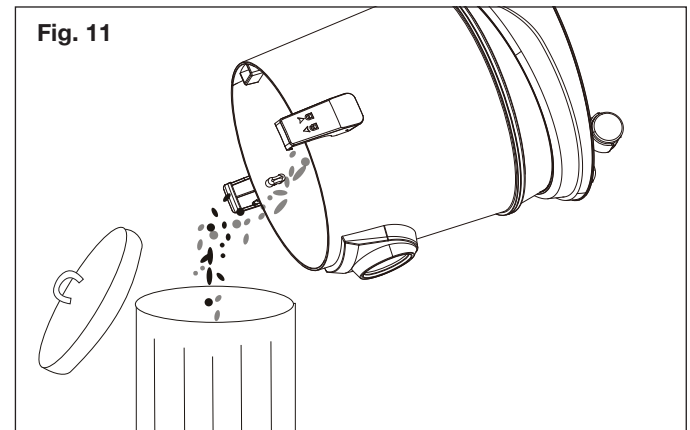

2. To re-assemble the inner housing components, lock the dust tube by rotating counter-clockwise. Then place all the components back into the dust tank in the order shown (Fig. 12).

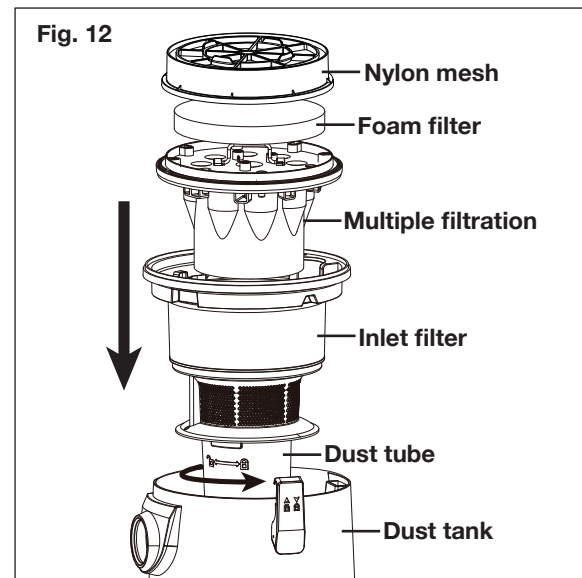

## Storage

1. Examine the electric wet/dry vacuum thoroughly for worn, loose or damaged parts. Should you need to repair or replace a part, contact an authorized Snow Joe® + Sun Joe® dealer or call the Snow Joe® + Sun Joe® customer service center at 1-866-SNOWJOE (1-866-766-9563) for assistance.
2. Examine the appliance cord thoroughly for signs of excess wear or damage. If it is worn or damaged, replace it immediately.
3. Store the wet/dry vacuum indoors in a clean, dry and locked location out of the reach of children and animals.
4. When not in use, the extension hose can be temporarily stored at the side of the unit by inserting the extension tube hook into the storage hook (Fig. 13).

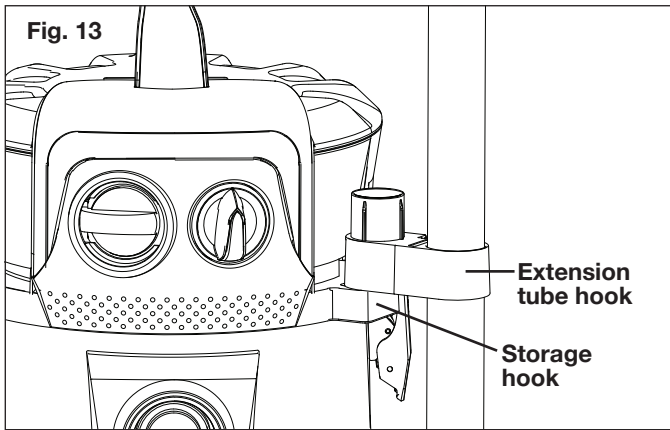

5. When not being used, the accessories can be temporarily stored at the back of the unit (Fig. 14).

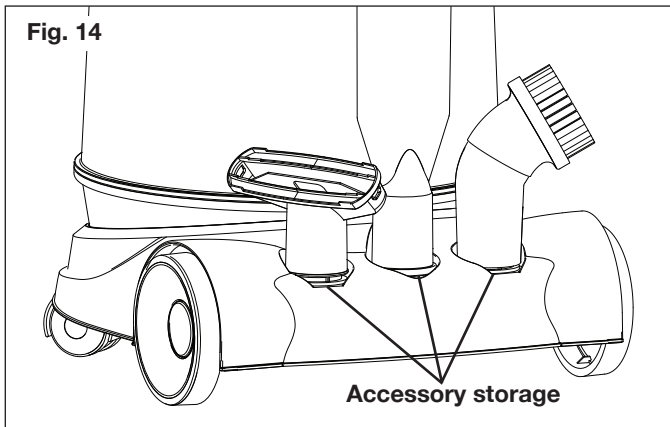

## Transportation

- Switch the product off.
- Always carry the product by its handle.
- If you are transporting the wet/dry vac in a vehicle, brace it properly to protect it from heavy impact or strong vibrations.
- Secure the product to prevent it from falling over or slipping.

## Recycling + Disposal

The product comes in a package that protects it against damage during shipping. Keep the package until you are sure that all parts have been delivered and the product is functioning properly. Recycle the package afterwards or keep it for long-term storage.



WEEE symbol. Waste electrical products should not be disposed of with household waste. Please recycle where facilities exist. Check with your local authority or local store for recycling regulations.

## Service and Support

If your Sun Joe® SWD4000 electric wet/dry vacuum requires service or maintenance, please call the Snow Joe® + Sun Joe® customer service center at 1-866-SNOWJOE (1-866-766-9563).

## Model and Serial Numbers

When contacting the company, reordering parts or arranging service from an authorized dealer, you will need to provide the model and serial numbers, which can be found on the decal located on the housing of the unit. Copy these numbers into the space provided below.

Record the following numbers from the housing or handle of your new product:	
Model #:	_____
S   W   D   4   0   0   0	_____
Serial #:	_____

# Troubleshooting

**⚠️ WARNING!** Always unplug the power cord before performing any adjustments, maintenance or repairs to your electric wet/dry vacuum.

<b>Problem</b>	<b>Possible Cause</b>	<b>Possible Solution</b>
Device does not start	Mains voltage is not present	Check power supply – cord, breakers, fuses. If damage is found, contact a qualified electrician to repair
	The equipment is not switched ON	Switch on the equipment
	The collection tank is full	Empty the collection tank
	Defective appliance cord or ON/OFF switch	Contact Snow Joe® customer service at 1-866-SNOWJOE (1-866-766-9563) to repair
	Defective motor	
Dust comes out from motor cover	The nylon mesh filter is missing or damaged	Attach or replace the nylon mesh filter
	There is a blockage in the nozzle, hose, or air inlet. The nylon mesh filter is clogged by fine dust	Check the unit for blockage. Clean or replace the nylon mesh filter.

## Optional Accessories

**⚠ WARNING!** ALWAYS use only authorized Snow Joe® + Sun Joe® replacement parts and accessories. NEVER use replacement parts or accessories that are not intended for use with this tool. Contact Snow Joe® + Sun Joe® if you are unsure whether it is safe to use a particular replacement part or accessory with your tool. The use of any other attachment or accessory can be dangerous and could cause injury or mechanical damage.

Accessories	Item	Model
<p>①</p> 	Wet/Dry Vac Replacement Filter	SWD4000-FTR

**NOTE:** Accessories are subject to change without any obligation on the part of Snow Joe® + Sun Joe® to provide notice of such changes. Accessories can be ordered online at [snowjoe.com](http://snowjoe.com) or via phone by contacting the Snow Joe® + Sun Joe® customer service center at 1-866-SNOWJOE (1-866-766-9563).





## SNOW JOE® + SUN JOE® CUSTOMER PROMISE

**ABOVE ALL ELSE**, Snow Joe® + Sun Joe® are dedicated to you, our customer. We strive to make your experience as pleasant as possible. Unfortunately, there are times when a product does not work or breaks under normal operating conditions. We think it's important that you know what you can expect from us. That's why we created the Snow Joe® + Sun Joe® promise.

**OUR PROMISE:** Snow Joe® + Sun Joe® warrant new products for two years from the date of purchase. If your product does not work, or there's an issue with a specific part, we will fix this by either sending you a free replacement part or by sending you a new or comparable product at no charge. How cool is that! Before you know it, you'll be back in action cutting, sawing, mowing, washing and...?

### PRODUCT REGISTRATION:

Snow Joe®, LLC ("Snow Joe® + Sun Joe®") strongly encourages you to register your purchase. You can register online at [snowjoe.com/ProductRegistration](http://snowjoe.com/ProductRegistration), or by printing and mailing in a registration card available online from our website, or calling our Customer Service Department at **1-866-SNOWJOE (1-866-766-9563)**, or by e-mailing us at [help@snowjoe.com](mailto:help@snowjoe.com). Failure to register your product purchase will not diminish your warranty rights. However, registering your purchase will allow Snow Joe® + Sun Joe® to better serve you with any of your customer service needs.

### WHO CAN SEEK WARRANTY COVERAGE?

This Warranty is extended by Snow Joe® + Sun Joe® to the owner of this Machine (a "Machine" consists of a product powered by a motor) for residential and personal household use only. This Warranty does not apply to products used for commercial, rental or re-sale purposes. Should ownership of this machine change during the 2-year period, please update the Machine's owner information at [snowjoe.com/ProductRegistration](http://snowjoe.com/ProductRegistration).

### WHAT IS COVERED?

Snow Joe® + Sun Joe® warrants to the owner that if this Machine fails within 2 years from the date of purchase due to a defect in material or workmanship or as a result of normal wear and tear from ordinary household use, Snow Joe® + Sun Joe® will send a replacement part or product, as needed, free of charge and with free shipping to the original purchaser.

If, in Snow Joe® + Sun Joe®'s sole discretion, the failed Machine cannot be repaired with a part, Snow Joe® + Sun Joe® will elect to either (A) send a new Machine at no charge and with free shipping or (B) refund the full purchase price to the owner.

### WHAT IS NOT COVERED?

This Warranty does not apply to the Machines that have been used commercially or in non-household applications. This Warranty does not cover cosmetic changes that do not affect performance. This Warranty is only valid if the Machine is used and maintained in accordance with the instructions, warnings and safeguards contained in the owner's manual. Snow Joe® + Sun Joe® will not be responsible for the cost of any unauthorized warranty repairs. This warranty does not cover any cost or expense incurred by the purchaser in providing substitute equipment or service during reasonable periods of malfunction or non-use of this product while waiting for a replacement part or unit under this warranty.

Wearing parts like belts, augers, chains and tines are not covered under this warranty, and can be purchased at [snowjoe.com](http://snowjoe.com) or by calling **1-866-SNOWJOE (1-866-766-9563)**. Batteries are covered in full for 90-days from the date of purchase.

Repair, replacement or refund of the purchase price are the exclusive remedies of purchaser and the sole liability of Snow Joe® + Sun Joe® under this warranty. No employee or representative of Snow Joe® + Sun Joe® is authorized to make any additional warranty or any modification to this warranty which may be binding upon Snow Joe® + Sun Joe®. Accordingly, purchaser should not rely upon any additional statements made by any employee or representative of Snow Joe® + Sun Joe®. In no event, whether based on contract, indemnity, warranty, tort (including negligence), strict liability or otherwise, shall Snow Joe® + Sun Joe® be liable for any special, indirect, incidental, or consequential damages, including, without limitation, loss of profit or revenue.

Some states do not allow limits on warranties. In such states, the above limitations may not apply to you.

Outside the USA, other warranties may apply.



[snowjoe.com](http://snowjoe.com)



This manual was downloaded from

# wet-dry-vac.com

The most comprehensive source of information about wet/dry shop vacuums on the Internet!

Wet-dry-vac.com allows you to learn about how to purchase a wet/dry vac, compare and review detailed specifications on hundreds of models, and find compatible filters.

You can also view manuals, parts lists and brochures for hundreds of models. Plus, you can find the best prices for vacuums and filters, and purchase online right from the site.

